

Features and Benefits

The LI-24 is a convenient wall mount cabinet for terminating and protecting up to 24 optical fibres in very little space. It accepts up to four 6-Pak Adapter Plates, providing a configurable unit for a variety of connector types.

The LI-24 is constructed of heavy gauge steel with a graphite grey powder coat finish. Optional clear Lexan patch cord protection shield is also available.

- Up to 24 Fibre ports
- Fully configurable using Molex Premise Networks' 6-Pak Adapter Plates

Technical Information

Mechanical Characteristics

Material: 16 Gauge (.06 thick) CRS
 Finish: Graphite Grey Powdercoat
 Optional Protective Shield: Clear Lexan
 Dimensions: 203mm H x 251mm W x 76mm D
 Ship Weight: 4 lbs. 6 oz. (2KG)

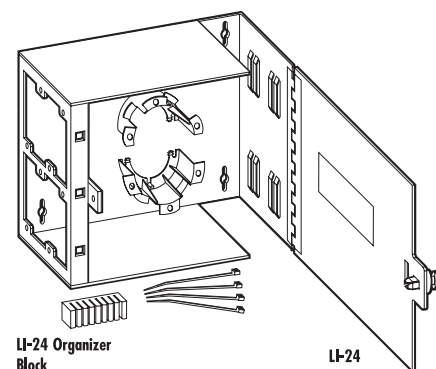
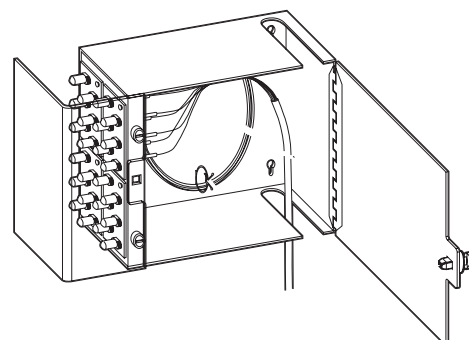

ORDERING INFORMATION

Order No.	SAP No.	Description
15.B016G	Consult Molex	LI-24 - Graphite Grey
30.B0330	Consult Molex	Patch Cord Protection Shield

MOLEX PREMISE NETWORKS

Americas
 Tel: 630 969 4550
 www.molexpn.com

EMEA
 Tel: 44 (0)2392 205800
 www.molexpn.co.uk

APAC
 Tel: 61 3 9971 7111
 www.molexpn.com.au