

Features and Benefits

Standard Grade Wall Mount Fiber Enclosures are configurable wall mount units for storing and terminating incoming fiber cable. The Standard Grade Wall Mount enclosures are available in two preconfigured styles accepting either two or four Fiber Pak/ Adapter Plates.

With the combination of high density/ fiber patching with the convenience of Fiber Pak/Adapter Plates—the end result is a unique combination of fiber density, ergonomics, durability and security in an aesthetically pleasing, cost effective wall mount enclosure.

- Utilized with Fiber Pak/Adapter Plates, which allow multiple fiber connector options and configurations.
- Two Styles Available, one accommodating 2 Fiber Pak/Adapter Plates and the other accommodating 4 Fiber Pak/Adapter Plates
- Utilized with Universal Splice Tray Carrier Kit (requires Universal Splice Tray Carrier Kit, sold separately) –Accommodates 2 Universal Splice Trays
- Divided and individually opened input and output demarcation areas
- Rubber gasket to limit dust and moisture ingress
- Two cable management spools
- Top and bottom cable entry points
- Durable steel construction
- Optional Keyed Lock Kit available to secure internal premise wiring of the enclosure
- Low profile
- Available in Almond or Black

Technical Information

Mechanical Characteristics

Panel: 16 Gauge Cold Rolled Steel
 Thickness: 1.5mm (.06")
 Finish: Almond or Black
 Cable Spools: Thermoplastic UL94V-O

Wall Mount Fiber Enclosure
 Dimensions: 260mm x 337mm x 89mm (10.25"H x 13.25"W x 3.5"D)
 Shipping Weight: 4.3kg (9 lbs. 8 oz.)

Universal Splice Tray Carrier Kit
 Dimensions: 31.75mm x 139.7mm x 16mm (1.25"H x 5.5"W x .63"D)
 Shipping Weight: 92.4g (3.3 oz.)

Reference Information

Fiber Enclosure (shipped assembled), includes:

- 2 Cable Ties
 - 2 cable management spools
 - 2 Grommets
 - 2 Hole Plugs
- Adhesive Port Label Sheet
- Fiber Warning Label
- Instruction Sheet

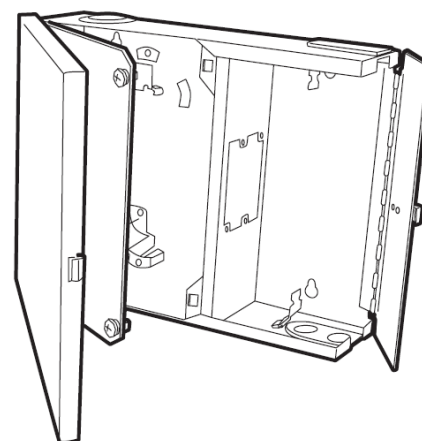

Wall Mount Fiber Enclosure

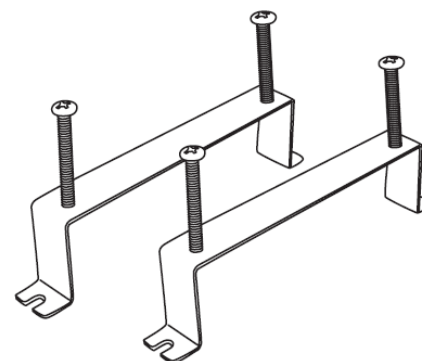

Universal Splice Tray Carrier Kit

ORDERING INFORMATION

Order No.	SAP No.	Description
WFR-00046*	Consult Molex	12-24 Port Standard Grade Wall Mount Fiber Enclosure
WFR-00047*	Consult Molex	24-48 Port Standard Grade Wall Mount Fiber Enclosure
35.B0130	Consult Molex	Keyed Lock Kit
AFR-00222	Consult Molex	Universal Splice Tray Carrier Kit

Note: Insert color code in place of * in part number when ordering.
 A = Almond, B = Black

MOLEX PREMISE NETWORKS

Americas
 Tel: 630 969 4550
 www.molexpn.com

EMEA
 Tel: 44 (0)2392 205800
 www.molexpn.co.uk

APAC
 Tel: 61 3 9971 7111
 www.molexpn.com.au